



# Forrestfield-Airport Link

Connect. Fly. Grow



Public Transport Authority



# Engineering Requirements

Jamie Mullins- Interface Manager, PTA



Public Transport  
Authority



# Route Alignment



# Station Layout- Airport West

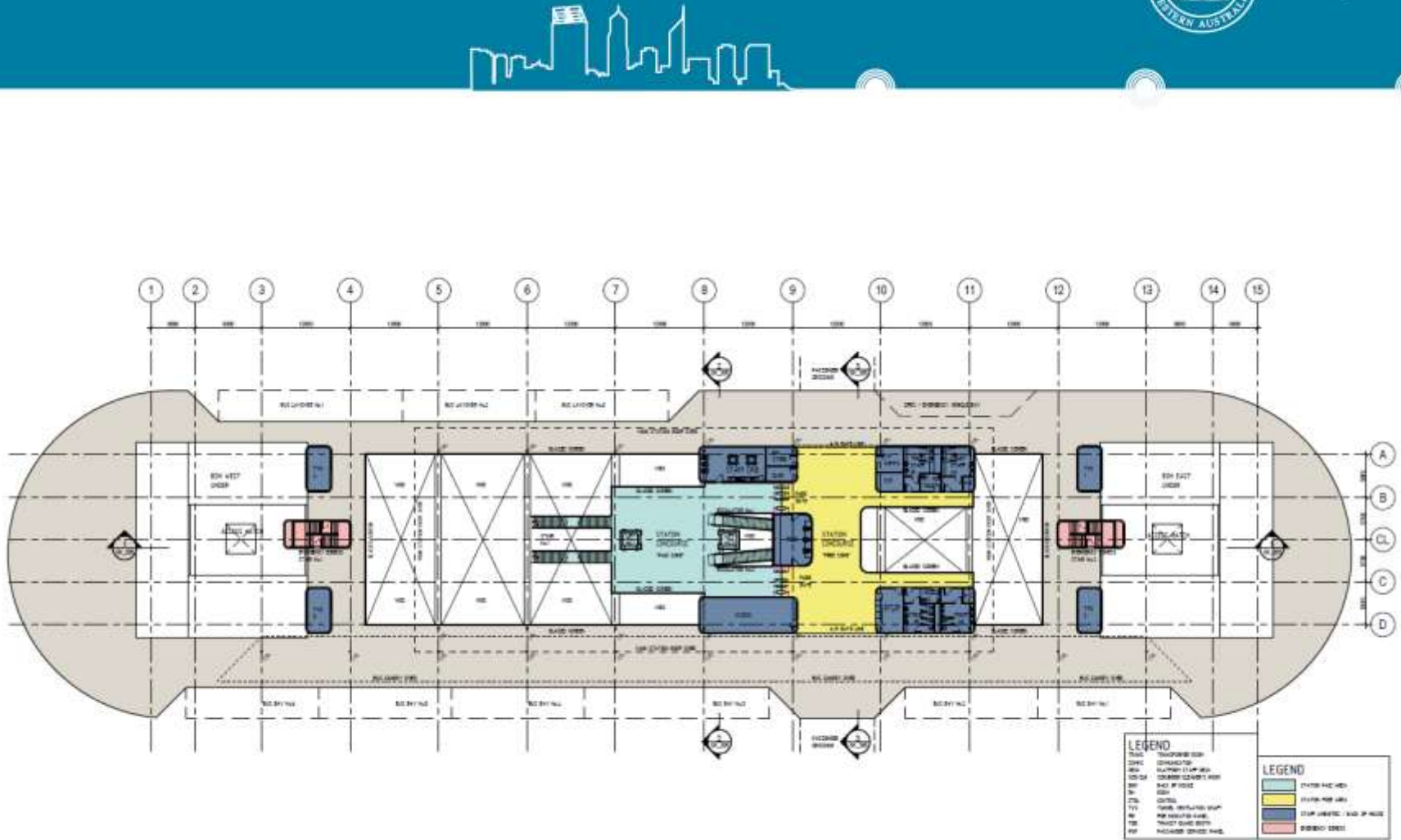

Drawings current as of April 2015- for illustrative purposes only.

# Station Layout

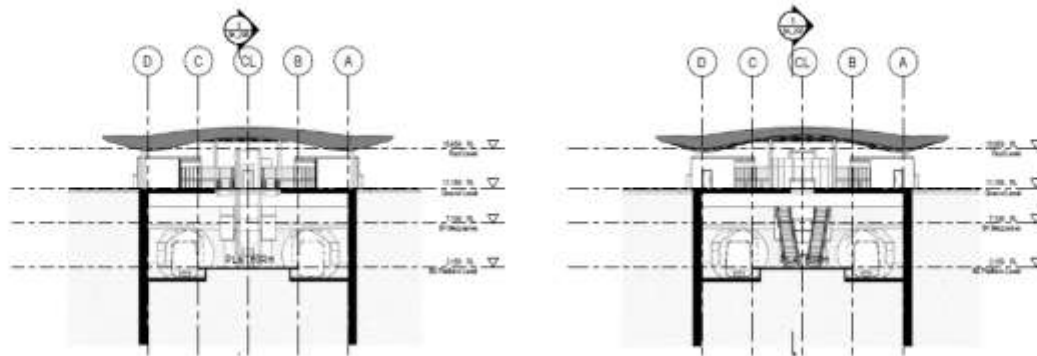
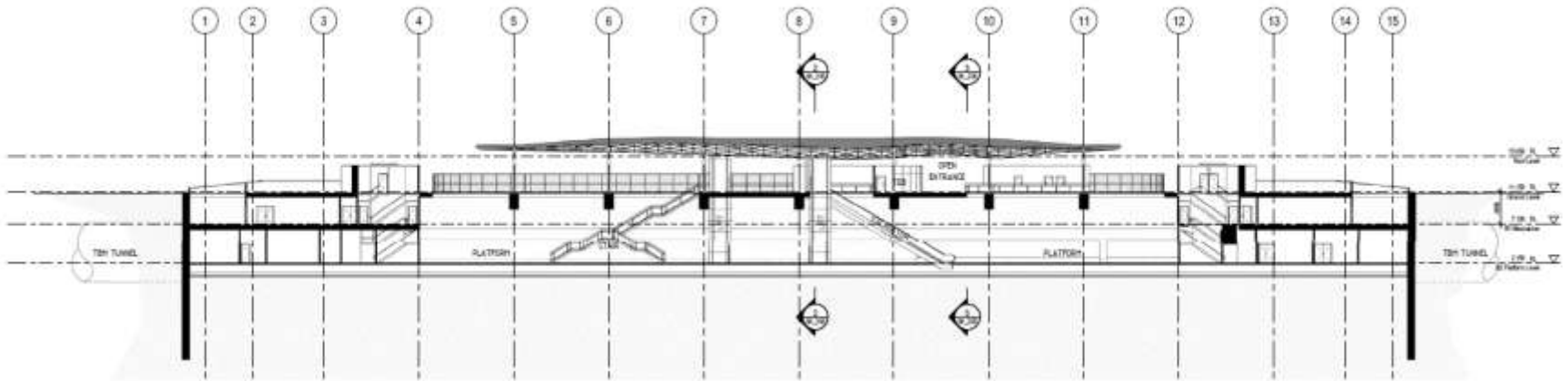

Drawings current at as April 2015- for illustrative purposes only.

# Station layout- Airport West

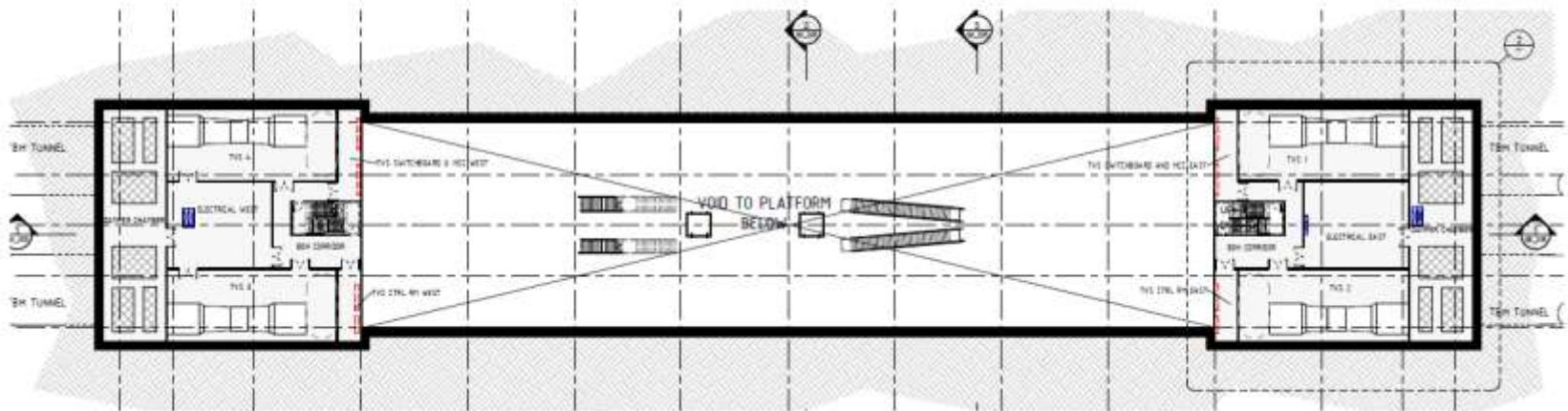
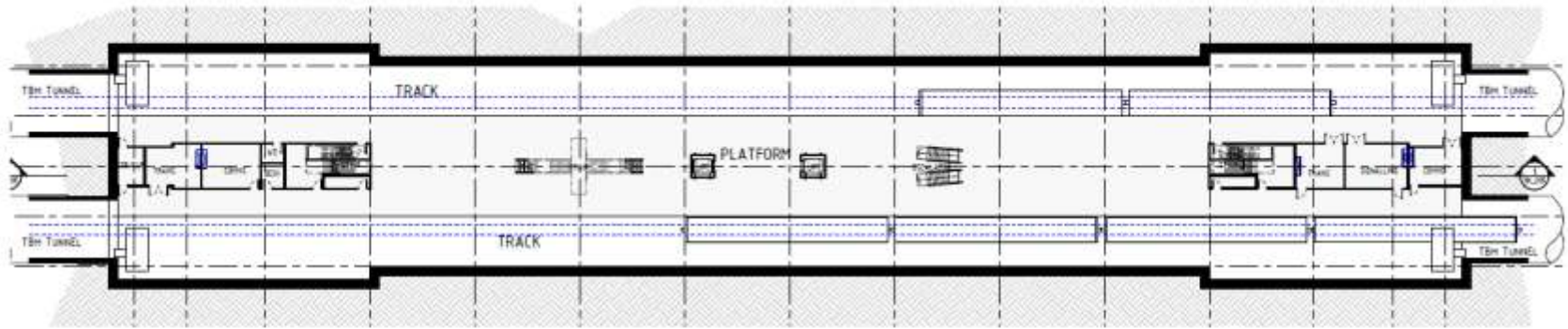

Drawings current at as April 2015- for illustrative purposes only.

# Cross Passages- Indicative examples

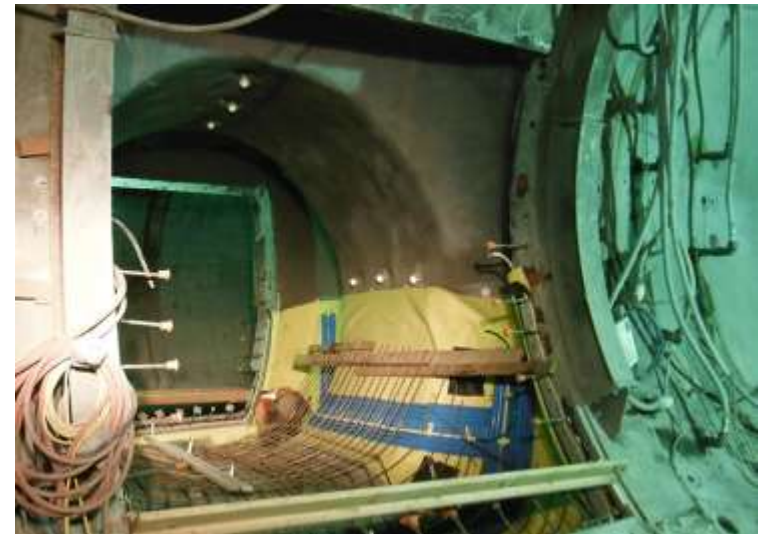
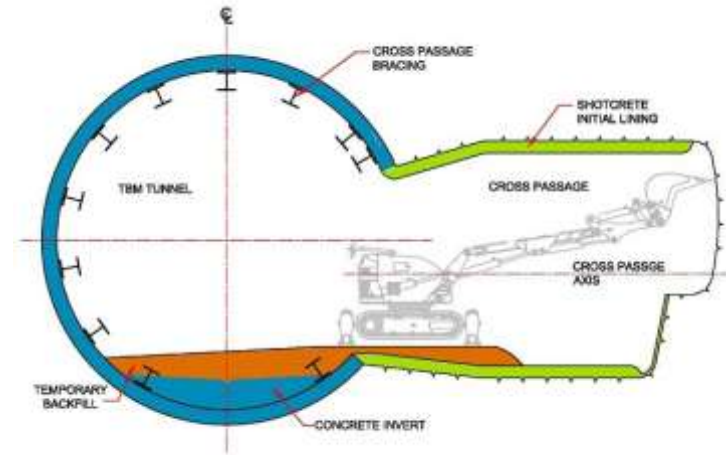
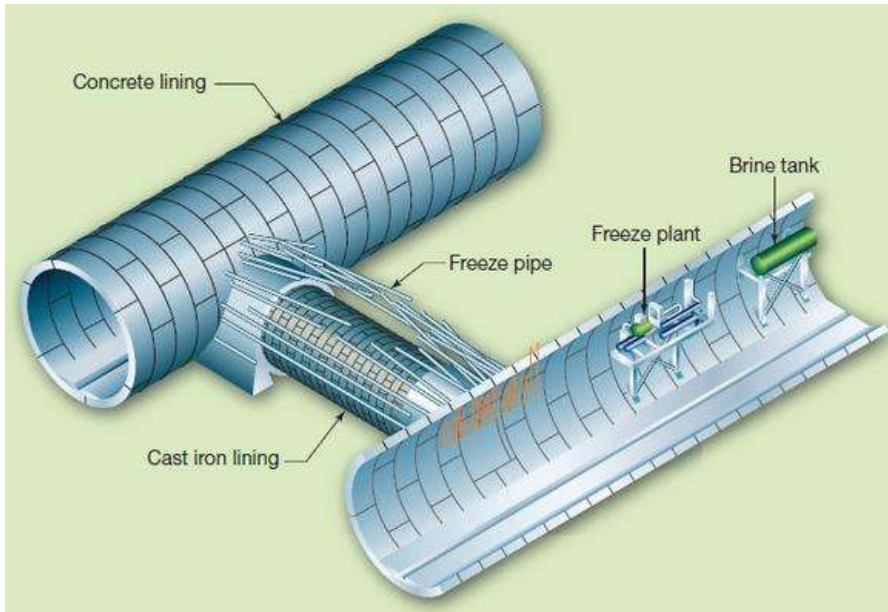



## Station Boxes

- Diaphragm Walls
- Top Down/Bottom Up Construction
- Dewatering

## Emergency Egress Shafts

- Diaphragm Walls
- Dewatering

## Bored Tunnelling

- Tunnel Boring Machine
- Pre-cast tunnel lining segments
- Commencing at Forrestfield (Staggered Start)

## Cross Passages

- Ground Stabilisation and sprayed concrete lining





# Tunnel Boring Machines- likely selections

Slurry Mixshield

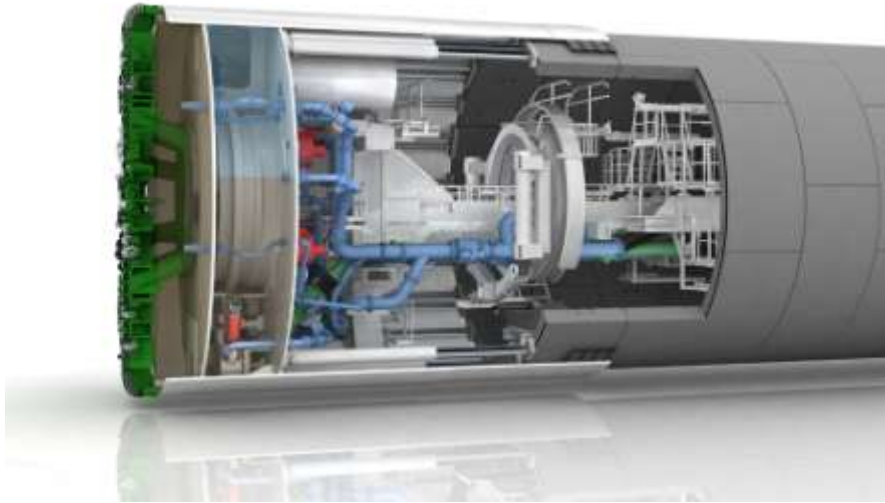

Earth Pressure Balance

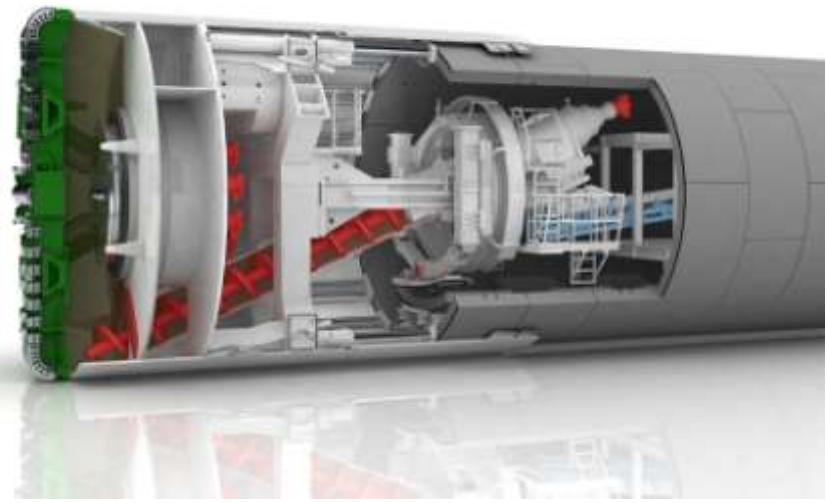





**Public Transport  
Authority**